

**Technical data**  
**Piling and drilling rig**

**LRB 125**  
Litronic®



**LIEBHERR**

# Concept and characteristics

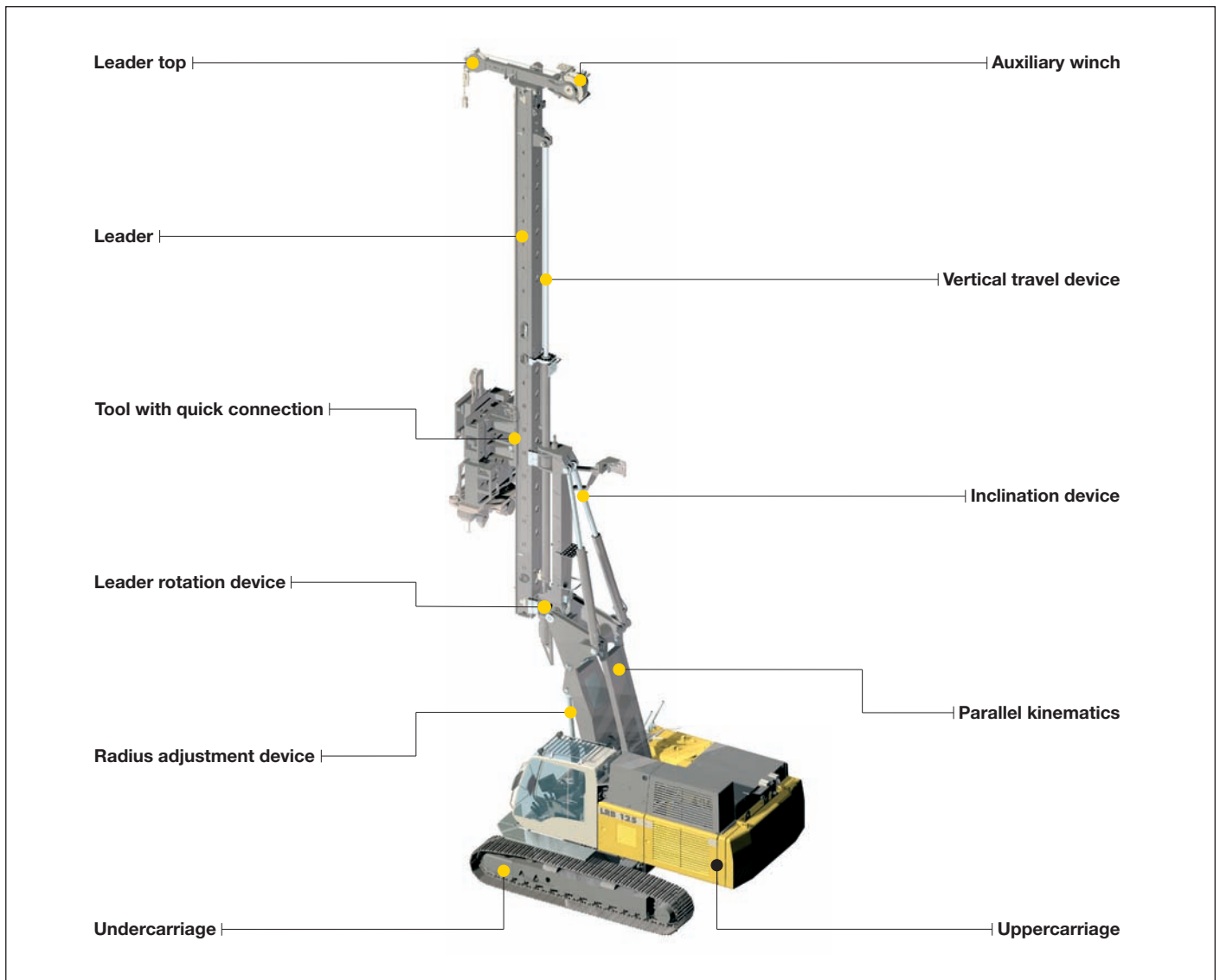

- High engine output with automatic engine speed control
- Controlled entirely from cab
- Sturdy and solid rig design
- Wide longitudinal and lateral supporting system on the basic machine through triangles
- High push and pull forces
- High torque
- Completely self-rigging (no auxiliary machines required)
- Large range of working tools (all piling and drilling works can be performed)
- Stepless leader inclination 1:6 forward – 1:3 backward depending on type of equipment
- Leader swing range  $\pm 90^\circ$
- Increase of effective leader length (5 m) via vertical travel device
- Automatic vertical alignment
- High alignment forces
- Simultaneous control of several movements via Load-sensing multi-circuit hydraulics
- Quick change of equipment possible through quick connection
- Equipment design according to latest European regulations and standards
- High manufacturing quality through quality control by PDE-system

# Transport dimensions and weights

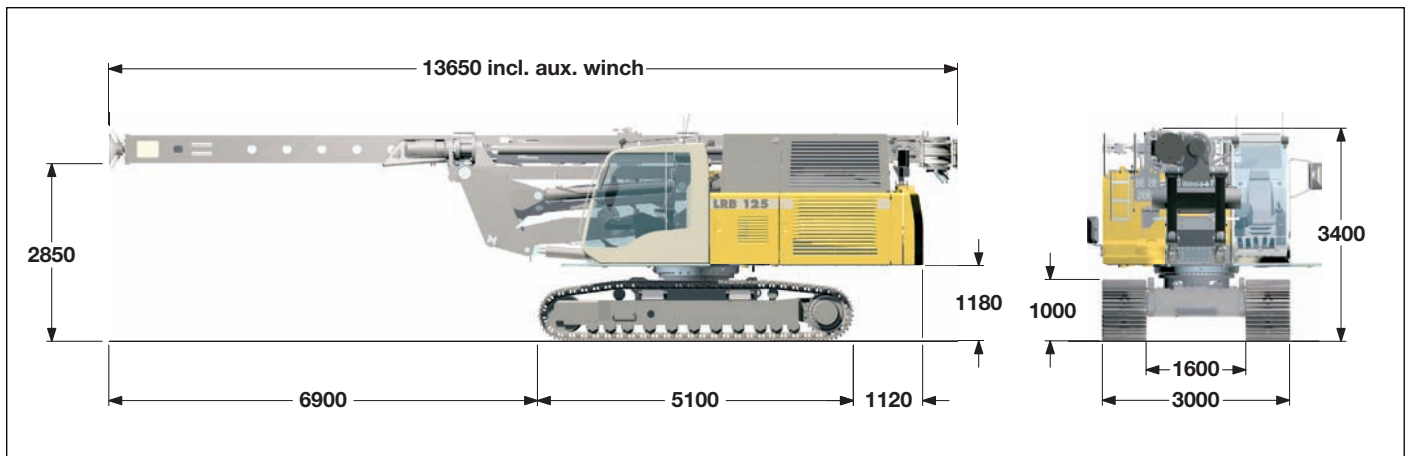

## Transport weight

Without attachment,  
with telescopic undercarriage and counterweight ———— 43 t

Without attachment and counterweight,  
with telescopic undercarriage ———— 39.1 t

Weights can vary with the final configuration of the machine.  
The figures in this brochure may include options which are not within  
the standard scope of supply of the machine.

# Dimensions

## Basic machine LRB 125

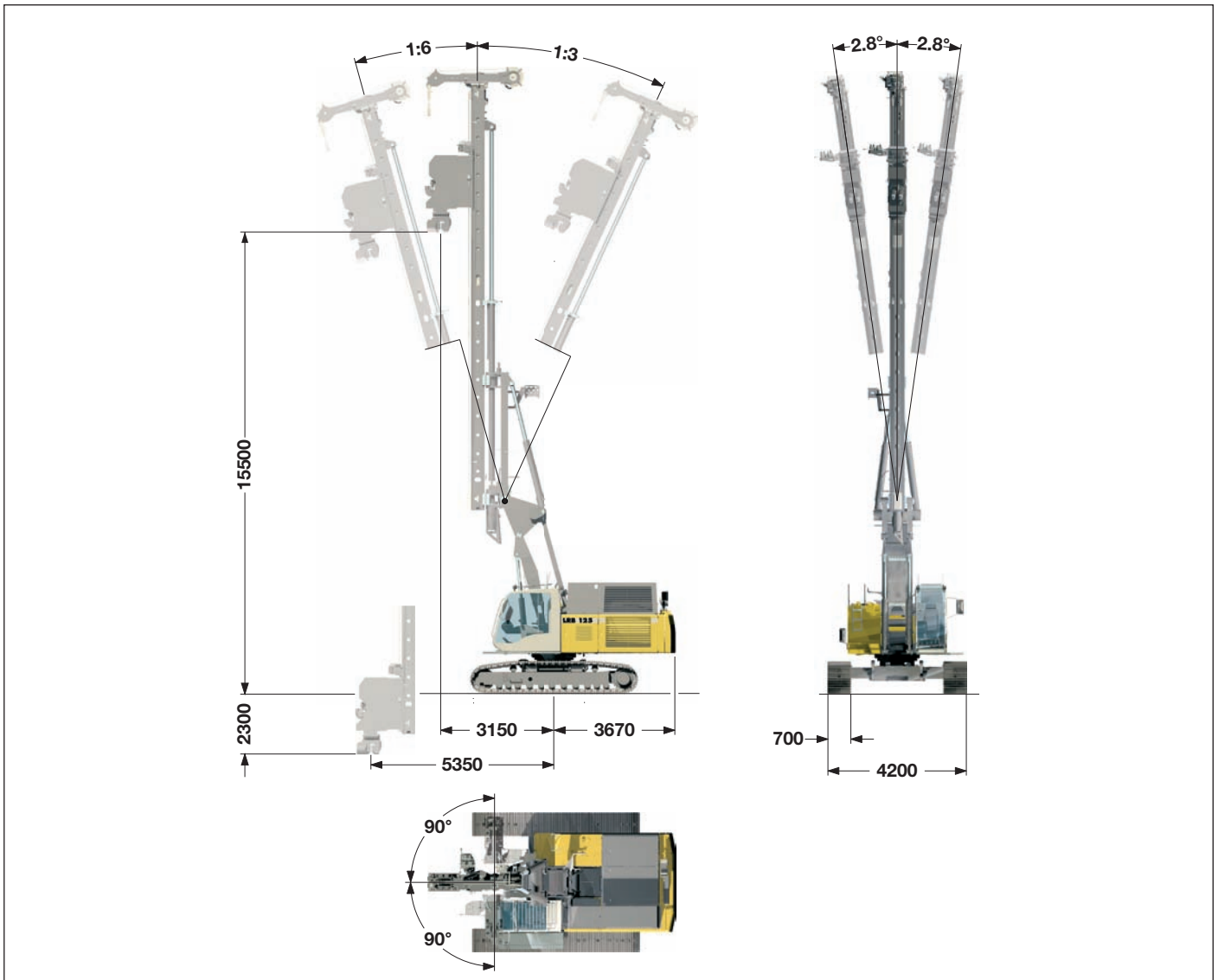

### Technical data

Leader length	12.5 m
Capacity hammer including cap plus pile	12 t
Max. hammer weight	6 t
Max. pile weight	6 t
Max. pull	200 kN
Max. torque	120 kNm
Working radius machine	
Center of rotation — center pile	3.15 — 5.35 m
Stepless rig inclination adjustment	
Lateral inclination	± 1:20
Forward inclination	1:6
Backward inclination	1:3
Vertical leader adjustment above ground level (depending on radius)	
Leader swing range	± 90°

### Operating weight and ground pressure

Telescopic undercarriage with 700 mm 3-web shoes 49 t – 0.83 kg/cm<sup>2</sup>

The operating weight includes the basic machine LRB 125 (leader length 12.5 m, with attachment). Weights can vary depending on the final configuration of the machine.

# Technical description



## Engine

Power rating according to ISO 9249, 450 kW (603 hp) at 1900 rpm  
Engine type \_\_\_\_\_ Liebherr D 9508 A7  
Fuel tank \_\_\_\_\_ 870 l capacity with continuous level indicator and reserve warning  
Engine complies with NRMM exhaust certification EPA/CARB Tier 3 and 97/68 EC Stage III.



## Hydraulic system

The main pumps are operated by a distributor gearbox. Axial piston displacement pumps work in open circuits supplying oil only when needed (flow control on demand).

The hydraulic pressure peaks are absorbed by the integrated automatic pressure compensation, which relieves the pump and saves fuel.

Pumps for working tools \_\_\_\_\_ 2x 350 l/min  
Separate pumps for kinematics \_\_\_\_\_ 2x 190 l/min  
Hydraulic oil tank \_\_\_\_\_ 825 l  
Max. working pressure \_\_\_\_\_ 350 bar

No auxiliary power packs are required as application specific hydraulics supply power to all components.  
The cleaning of the hydraulic oils occurs via an electronically monitored pressure and return filter.  
Any clogging is shown on the display in the cab.  
The use of synthetic environmentally friendly oil is also possible.



## Crawlers

Propulsion through axial piston motor, hydraulically released spring loaded multi-disc brake, maintenance free crawler tracks, hydraulic chain tensioning device.

Drive speed \_\_\_\_\_ 0 – 2.3 km/h  
Track force \_\_\_\_\_ 437 kN  
Width of 3-web track shoes \_\_\_\_\_ 700 mm



## Noise emission

Noise emissions correspond with 2000/14/EC directive on noise emission by equipment used outdoors.



## Swing

Consists of single row ballbearing, fixed axial piston hydraulic motor, spring loaded and hydraulically released multi-disc holding brake, planetary gearbox and pinion.  
Swing speed from 0 – 3.3 rpm is continuously variable.



## Control

The control system – developed and manufactured by Liebherr – is designed to withstand extreme temperatures and the many heavy-duty construction tasks for which this machine has been designed. Complete machine operating data are displayed on a high resolution monitor screen.

To ensure clarity of the information on display, different levels of data are shown in enlarged lettering and symbols. Control and monitoring of the sensors are also handled by this high technology system. Error indications are automatically displayed on the monitor in clear text.

The machine is equipped with proportional control for all movements, which can be carried out simultaneously.

Two joysticks are required for operation. Pedal control can be changed to hand control.

Options :

PDE : Process data recording  
GSM modem



## Auxiliary winch

Line pull (effective) \_\_\_\_\_ 50 kN  
Rope diameter \_\_\_\_\_ 17 mm  
Drum diameter \_\_\_\_\_ 420 mm

The winch is noted for compact, easily mounted design.

Propulsion is via a maintenance-free planetary gearbox in oil bath. Load support by the hydraulic system; additional safety factor by a spring-loaded, multi-disc holding brake.



## Rope crowd system

Crowd force push/pull \_\_\_\_\_ 150/200 kN  
Line pull (nominal load) \_\_\_\_\_ 100 kN  
Rope diameter \_\_\_\_\_ 18/20 mm

The ropes are actuated by a powerful hydraulic cylinder.

# High frequency vibrator slim design

## Model 1100 H



Effective length – 15.5 m

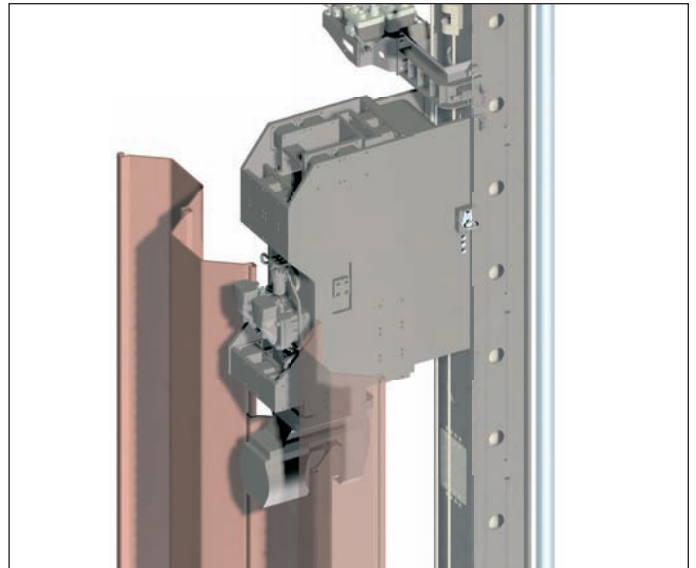

Vibrating of single pile between two other piles

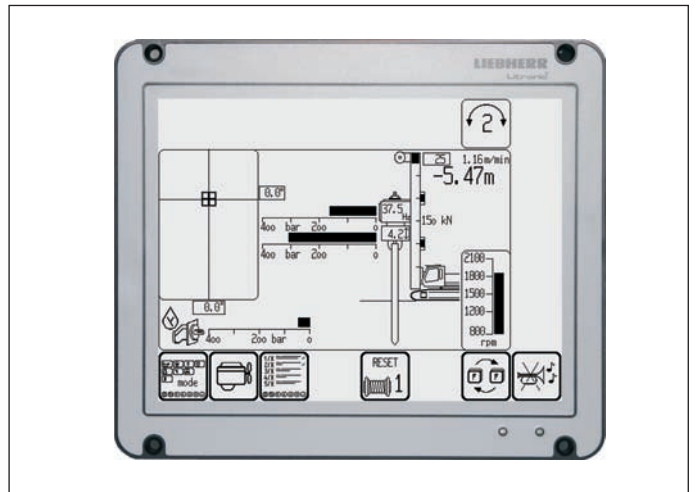

Display for vibrating

### Technical data

Static moment	0 – 20 kgm
Max. frequency	2300 rpm
Max. centrifugal force	1160 kN
Max. amplitude	19 mm
Total weight without clamp	3250 kg
Total weight with single clamp	4200 kg
Dynamic weight with clamp	2980 kg

# High frequency vibrator

## Model 23 VML with hydraulic sheet pile feeder



Effective length – 15.5 m

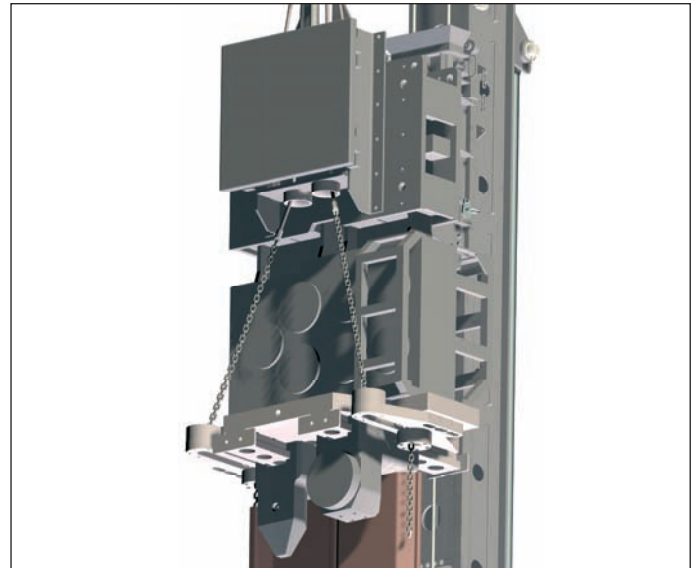

Double clamp and hydraulic sheet pile feeder

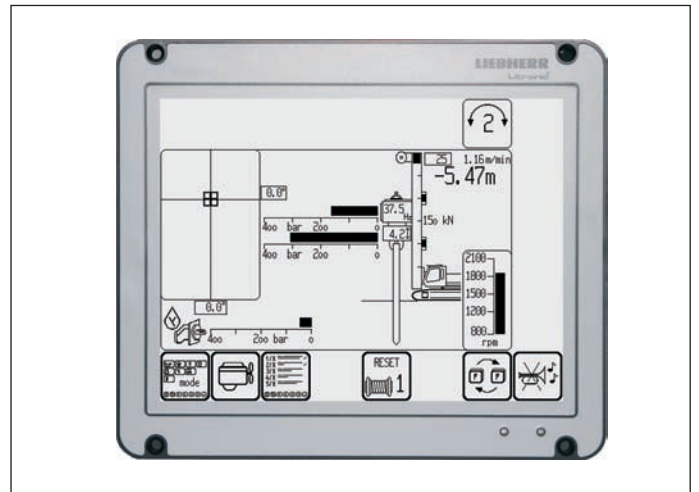

Display for vibrating

### Technical data

Static moment	0 – 23 kgm
Max. frequency	2300 rpm
Max. centrifugal force	1350 kN
Max. amplitude	17 mm
Total weight without clamp	4000 kg
Dynamic weight incl. clamp	5250 kg

# Pre-drill

## Model BA 45



Effective length – 15.5 m

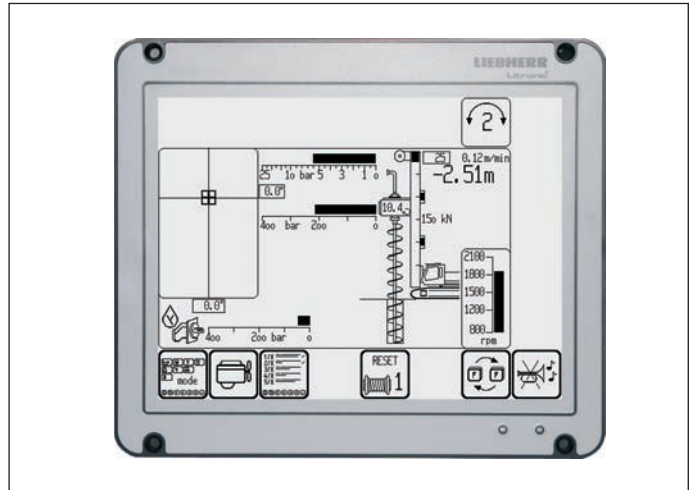

Display for continuous flight auger drilling

### Technical data

Drilling drive – torque	45 kNm
Drilling drive – speed	95 rpm
Max. drilling diameter	800 mm



# High frequency ring vibrator

## Model 20 VMR



Effective length – 27 m

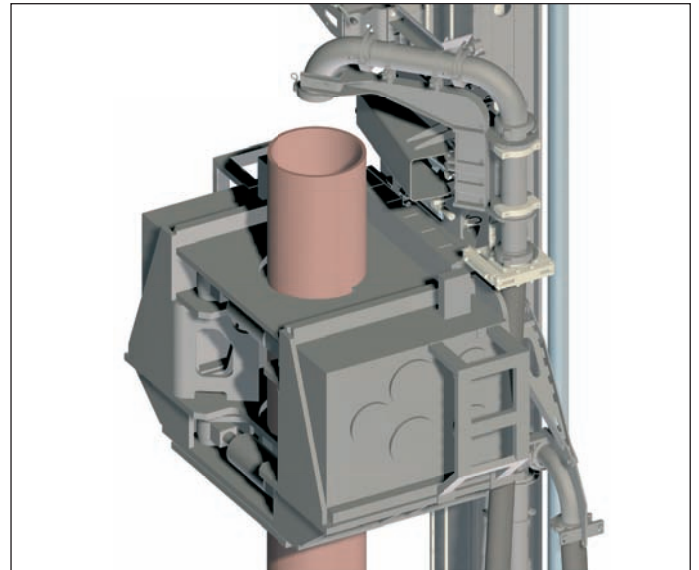

Concrete supply system

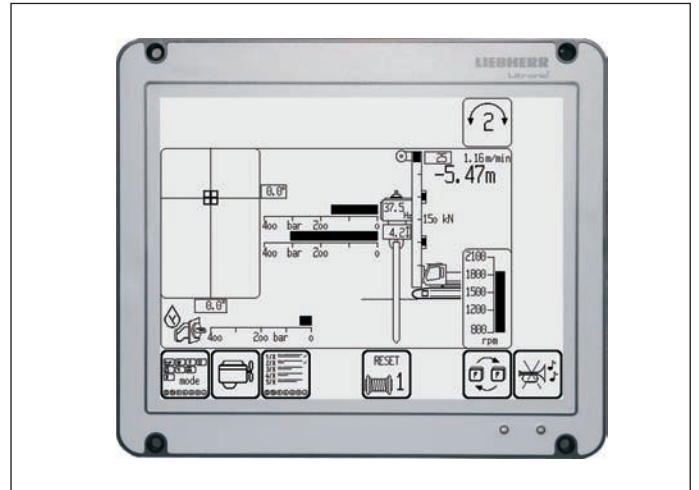

Display for vibrating

### Technical data

Static moment	0 – 20 kgm
Max. frequency	2300 rpm
Max. centrifugal force	1160 kN
Diameter	355 – 510 mm
Total weight	6200 kg

# Hydraulic hammer

## Model H 50



Effective length – 13.5 m

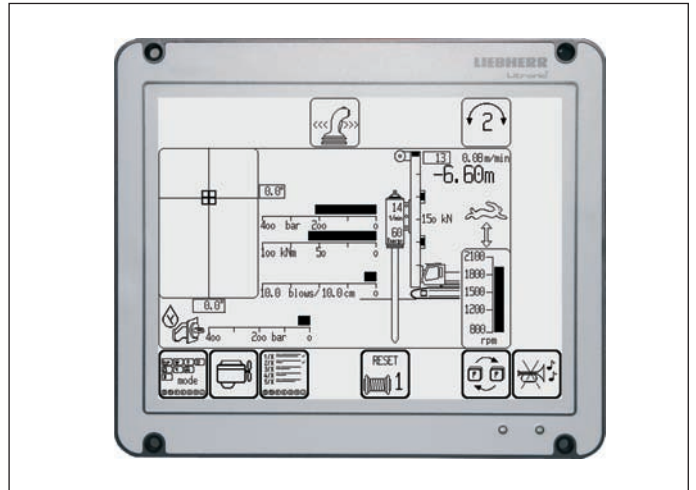

Display for impact driving

### Technical data

Ram mass	4000 kg
Max. rated energy	51 kNm
Blow rate max. energy	50 blows/min
Max. blow rate	100 blows/min
Basic hammer weight	8000 kg

# Double rotary drilling

## Model DBA 80



Effective length – 12.8 m

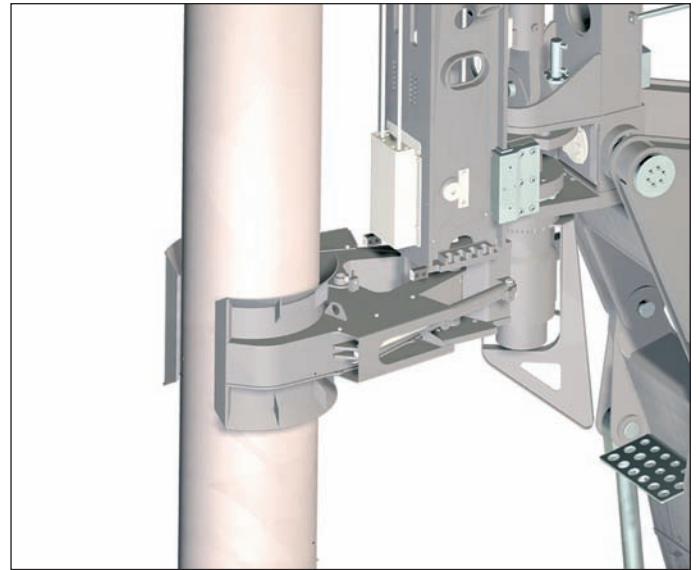

Hydraulic casing guide

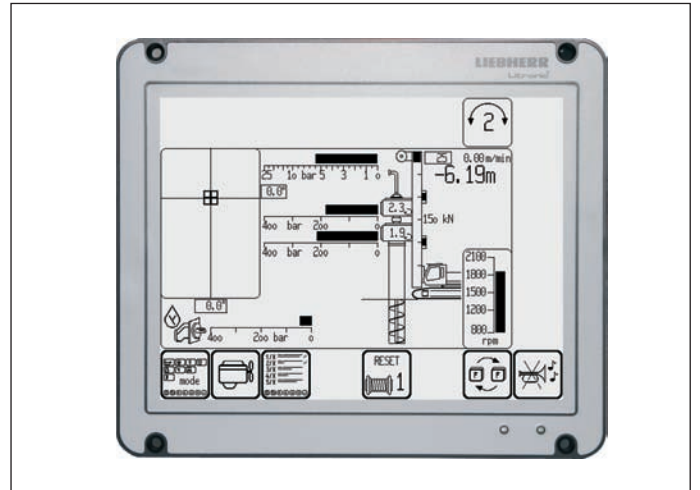

Display for double rotary drilling

### Technical data

Drilling drive I – torque	1 <sup>st</sup> gear	80 kNm
Drilling drive I – speed	1 <sup>st</sup> gear	18 rpm
Drilling drive I – torque	2 <sup>nd</sup> gear	40 kNm
Drilling drive I – speed	2 <sup>nd</sup> gear	36 rpm
Drilling drive II – torque	1 <sup>st</sup> gear	60 kNm
Drilling drive II – speed	1 <sup>st</sup> gear	24 rpm
Drilling drive II – torque	2 <sup>nd</sup> gear	30 kNm
Drilling drive II – speed	2 <sup>nd</sup> gear	48 rpm
Max. drilling diameter		620 mm

# Kelly drilling

## Model BA 150 and Kelly bar 12/3/20



Shock absorber for Kelly bar

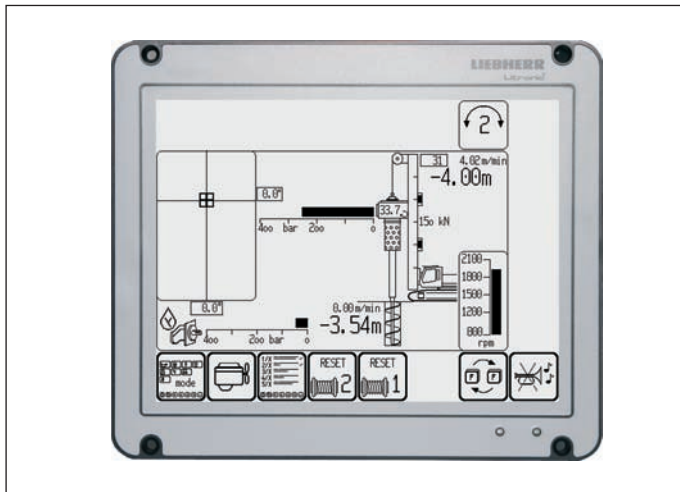

Display for Kelly drilling

### Technical data

Drilling drive – torque	1 <sup>st</sup> gear	120 kNm
Drilling drive – speed	1 <sup>st</sup> gear	32 rpm
Drilling drive – torque	2 <sup>nd</sup> gear	60 kNm
Drilling drive – speed	2 <sup>nd</sup> gear	60 rpm

### Technical data Kelly bar

Diameter	305 mm
Number of sections	3
Extended length	20.5 m
Retracted length	8.5 m
Drive stub	200 mm
Weight	3200 kg

### Technical data Kelly winch

Line pull (effective)	110 kN
Winch speed	0 – 100 m/min

### Performance data

Max. drilling diameter	1200 mm
Max. drilling depth*	18 m
Max. clearance below drilling tool	6.5 m

\*) other Kelly bars on request

# Continuous flight auger drilling

## Model BA 150



Effective length – 14.6 m

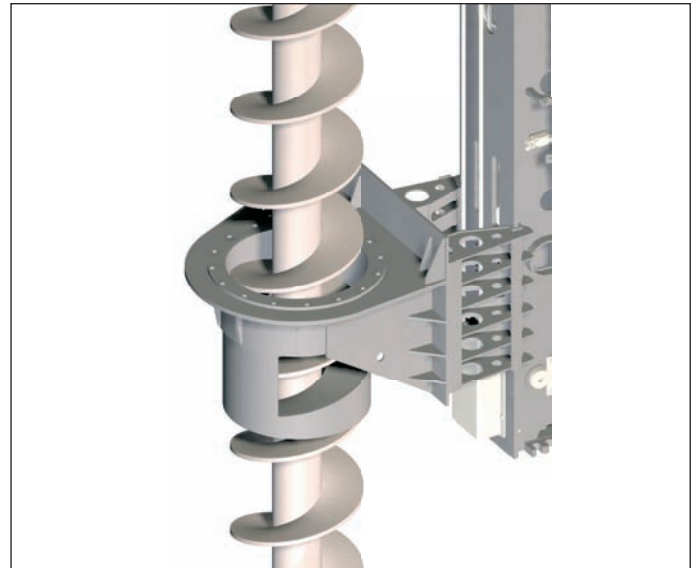

Auger with hydraulic auger cleaner

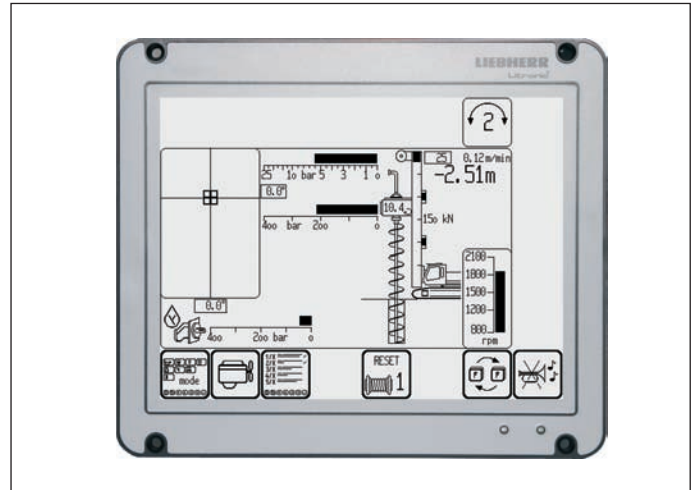

Display for continuous flight auger drilling

### Technical data

Drilling drive – torque	1 <sup>st</sup> gear	120 kNm
Drilling drive – speed	1 <sup>st</sup> gear	32 rpm
Drilling drive – torque	2 <sup>nd</sup> gear	60 kNm
Drilling drive – speed	2 <sup>nd</sup> gear	60 rpm
Max. drilling diameter		800 mm

# Twin mix equipment

## Model DMA 35



Effective length – 15.2 m

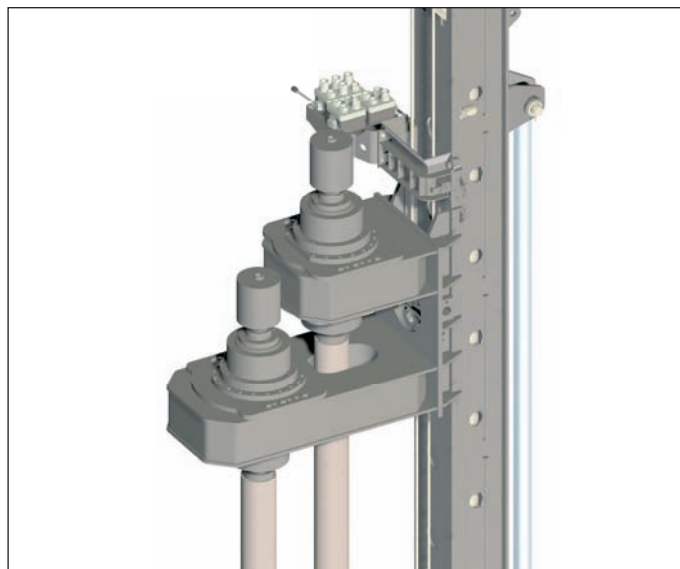

Set up for operation on dams

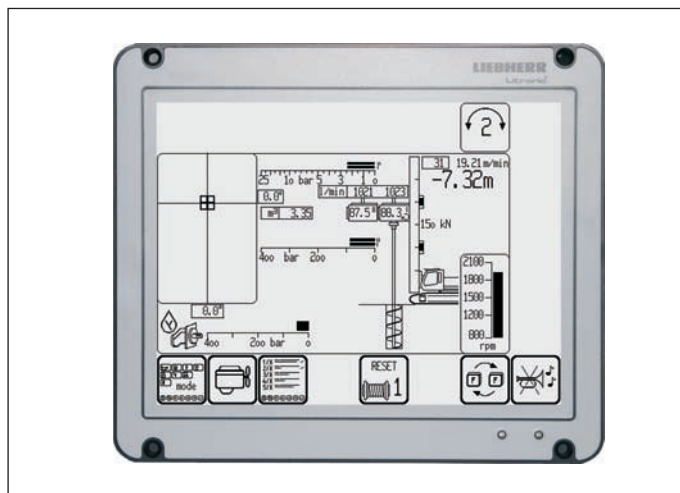

Display for soil mixing

### Technical data

Drilling drive – torque	1 <sup>st</sup> gear	35 kNm
Drilling drive – speed	1 <sup>st</sup> gear	60 rpm
Drilling drive – torque	2 <sup>nd</sup> gear	17.5 kNm
Drilling drive – speed	2 <sup>nd</sup> gear	120 rpm



